



Preventing Capacitor Arc-Over in Lighting Applications with HVArc Guard® MLCCs

A series of recent high-voltage multilayer ceramic capacitor (MLCC) technology breakthroughs at Vishay have resulted in a new range of surface-mount MLCCs that are better suited for the ballast application than any previous type of capacitor. These new HVArc® Guard capacitors are presently available with NP0 and X7R dielectrics and voltage ratings currently offered from 250 V to 1000 V_{DC}.

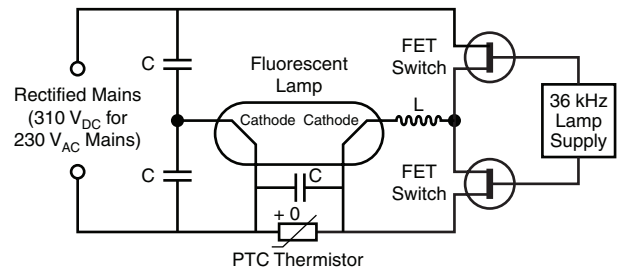

Figure 1. - Typical electronic ballast circuit

Advantages of New HVArc Guard Capacitors for Lighting Applications

MLCCs used in lighting ballast circuits can be exposed to high voltages, over 1000 V_{DC} in air. A block diagram of typical lighting ballast is shown in Figure 1. The capacitors are prone to both surface-arc-over and internal breakdown. In either event, failure may result when surface arc-over causes the circuit to be de-stabilized, which may in turn cause damage to surrounding components even if the capacitor remains temporarily functional. The unique HVArc Guard capacitor design prevents arc-over while allowing the use of smaller case sizes in lighting ballast applications.

Until now, MLCCs in the larger 1210, 1808 and 1812 cases have been used in high-voltage lighting ballast applications. New HVArc Guard high-voltage MLCCs can replace many of these standard high voltage capacitors in ballast circuits, allowing more compact designs while reducing component cost.

TABLE 1 - HOW NEW HVArc GUARD CAN SAVE PRINTED CIRCUIT BOARD SPACE IN LIGHTING APPLICATIONS					
CAPACITOR	DIELECTIC	VOLTAGE (V)	TYPICAL HIGH-VOLTAGE CASE SIZE	REPLACE WITH HVArc GUARD CASE SIZE	HVArc GUARD PART NUMBER
100 pF	COG	630	1206	0805	VJ0805A101KXLAT5Z
47 pF	COG	630	1206	0805	VJ0805A470KXLAT5Z
22 pF	COG	3000	1808	1808	Available soon
1 nF	COG	500	1210	1210	VJ1210A102KXEAT5Z

Table 1 compares standard high-voltage MLCCs and the HVArc Guard replacements for lighting ballast applications. For example, a common 630 V MLCC in a 1206 case (0.126 in. by 0.063 in.) can be replaced with an HVArc

Guard MLCC in the 0805 case (0.079 in. by 0.049 in.). Using HVArc Guard can provide board space savings of 50 % or more.

APPLICATION NOTE



Preventing Capacitor Arc-Over in Lighting Applications with HVArc Guard[®] MLCCs

The small size dimensions and high-voltage breakdown performance of HVArc Guard surface-mount MLCCs make these devices ideal for compact electronic fluorescent lighting ballasts, where they will be used in the high-voltage

inverter section. Their breakdown voltage is in fact more than twice that of the comparable standard high-voltage capacitor. More information on voltage capability can be found below.

Eliminating Costly Over-Coatings with HVArc Guard Capacitors

Until now, designers have needed to use various costly measures, such as over-coatings, to prevent electrical arc-over in high-voltage applications. Although coatings add cost to the process and the design, they are often required in some applications to meet electrical safety standards. In some applications, older coated leaded through-hole capacitors are used to avoid having to over-coat the components.

The special internal shield construction of Vishay HVArc Guard eliminates the need for coating the part to prevent surface electrical arc-over. HVArc Guard is a good alternative to older-technology coated leaded through-hole capacitors and will result in process cost savings since costly manual insertion processes associated with through-hole devices can be eliminated.

Improved Voltage Breakdown Capability with HVArc Guard Capacitors

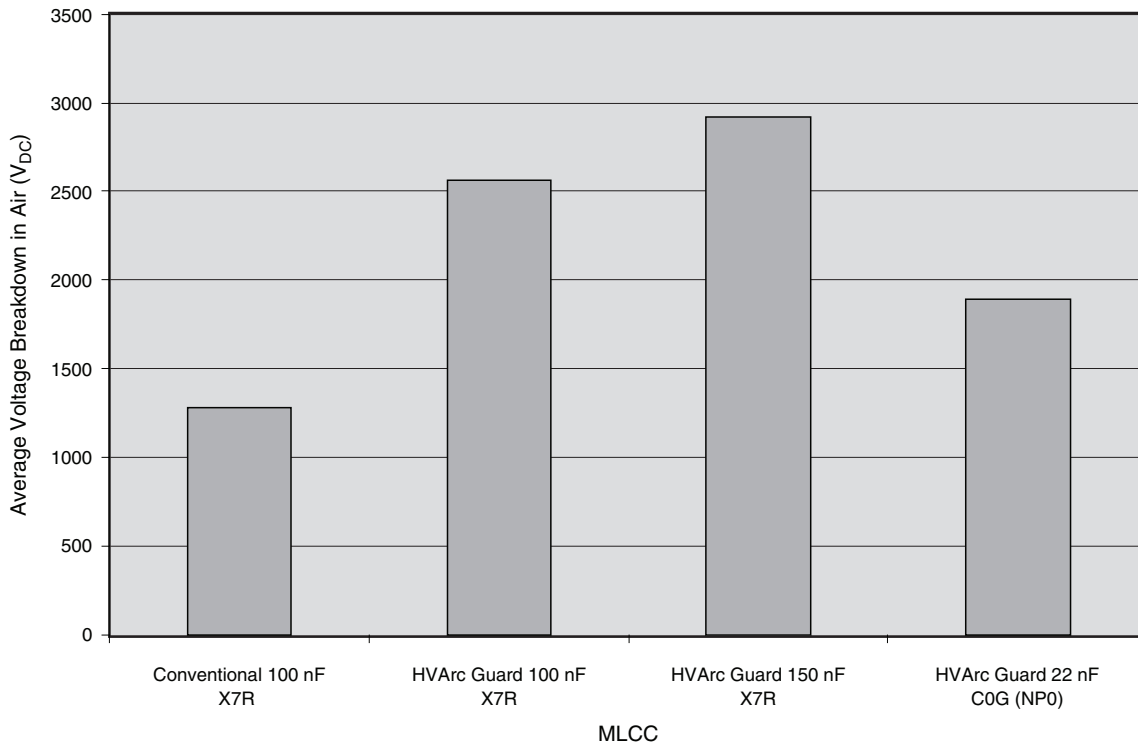

HVArc Guard capacitors provide an improved voltage breakdown capability compared to standard high-voltage capacitors. The bar chart compares standard high-voltage 1812 size capacitors to new HVArc Guard capacitors.

Because the HVArc Guard capacitors prevent surface-arc-over, their voltage breakdown in air is more than twice that of conventional standard high-voltage capacitors.

APPLICATION NOTE

Preventing Capacitor Arc-Over in Lighting Applications with HVArc Guard® MLCCs

Using HVArc Guard in Lighting Control Circuitry

In lighting control circuitry the power is sourced from rectified AC mains as shown in the schematic below. Pre-converters are also used in many ballast circuits and have a power factor approaching unity. The pre-converter supplies an output voltage that is regulated with very high accuracy. The filaments in florescent lamps require pre-heating followed by a very high start-up/ignition voltage to light the bulb. Once the ignition occurs and the lamp is conducting, the basic circuit appears as an inductor in series with a parallel resistor and a capacitor.

The input voltage is derived from the AC main and is a sine wave. To make the input current shaped like the line voltage, the converter produces a boost inductor current like the rectified input voltage. A regulated voltage is delivered to the ballast section of the circuit from the diode bridge. When the ballast section is operational, the current pump consisting of the capacitor snubber ($C_{snubber}$) and the diodes limits the rise and fall time of the bridge output. The snubber is also used to reduce EMI.

Many lighting ballasts use two power MOSFET switches in a configuration as shown in Figure 2. The MOSFETs alternate between driving and conducting the transformer windings.

This fundamental circuit has been the industry standard for lighting ballast for many years but it has a few drawbacks. There is no self-start feature, and light dimming capability is not part of the circuit. Also a large transformer is needed for proper operation.

New advances in driver ICs have resulted in major improvements in lighting ballast. These circuits can drive low- and high-side MOSFETS from logic-level/ground-referenced inputs rather than needing a driver transformer. Figure 3 is an example showing the various capacitors needed for the ballast circuit.

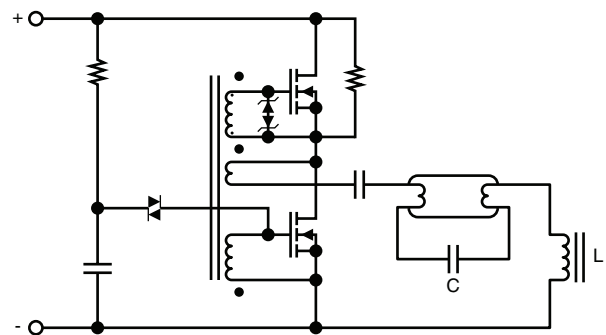

Figure 2.

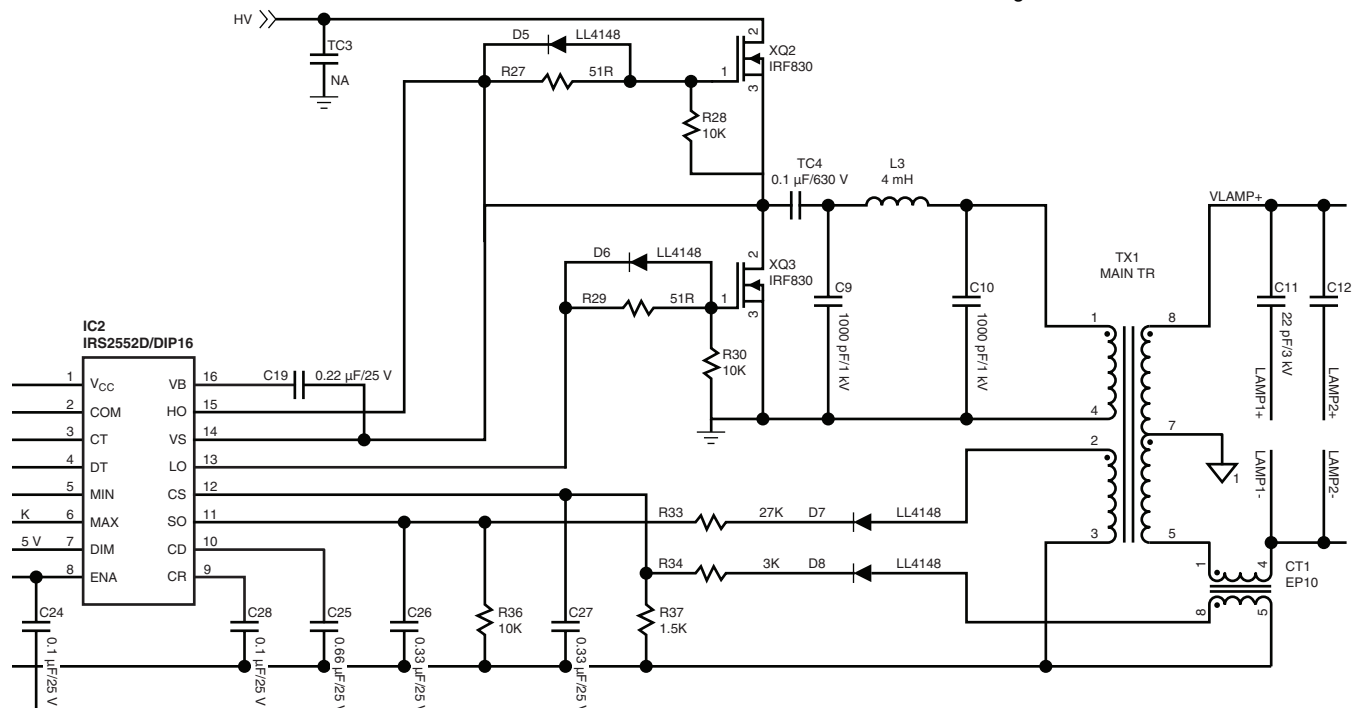

Figure 3.

Preventing Capacitor Arc-Over in Lighting Applications with HVArc Guard[®] MLCCs

HVArc Guard capacitors Ordering Information

HVArc Guard MLCCs are available in both COG (NP0) and X7R dielectrics and in a variety of popular surface-mount

EIA standard case sizes. Ordering is easy using the codes below.

HVArc Guard NP0 Dielectric Ordering Code

ORDERING INFORMATION								
VJ0805	A	102	J	X	G	A	T	5Z
CASE CODE	DIELECTRIC	CAPACITANCE NOMINAL CODE	CAPACITANCE TOLERANCE	TERMINATION	DC VOLTAGE RATING ¹⁾	MARKING	PACKAGING	PROCESS CODE
0805 1206 1210	A = COG	Expressed in picofarads (pF). The first two digits are significant, the third is a multiplier. Examples: 102 = 1000 pF	J = ± 5 % K = ± 10 % M = ± 20 %	X = Ni barrier 100 % tin plated matte finish F = AgPd	G = 1000 V R = 1500 V	A = Unmarked	C = 7" reel/ paper tape T = 7" reel/ plastic tape P = 11 1/4" reel/ paper tape B = Bulk R = 11 1/4" reel/ plastic tape W = Waffle tray	5Z = HVArc Guard

Note:

1. DC voltage rating should not be exceeded in application

HVArc Guard X7R Dielectric Ordering Code

ORDERING INFORMATION								
VJ1812	Y	102	J	X	P	A	T	5Z
CASE CODE	DIELECTRIC	CAPACITANCE NOMINAL CODE	CAPACITANCE TOLERANCE	TERMINATION	DC VOLTAGE RATING ¹⁾	MARKING	PACKAGING	PROCESS CODE
1206 1210 1808 1812	Y = X7R	Expressed in picofarads (pF). The first two digits are significant, the third is a multiplier. Examples: 223 = 22 000 pF	J = ± 5 % K = ± 10 % M = ± 20 %	X = Ni barrier 100 % tin plated F = AgPd	P = 250 V E = 500 V L = 630 V G = 1000 V	A = Unmarked	C = 7" reel/ paper tape T = 7" reel/ plastic tape P = 11 1/4" reel/ paper tape B = Bulk R = 11 1/4" reel/ plastic tape W = Waffle tray	5Z = HVArc Guard

Note:

1. DC voltage rating should not be exceeded in application